

FEATURES:

- All brass construction, Independent corner valves  
Includes lift & turn style drain assembly.
- Requires 1-1/4" Dia. mounting holes.
- Extended wall vessel spout, 9-3/4" long, available P/N: 18.17.073
- Quarter turn ceramic disc valve cartridge.
- Available in all finishes. Warranty varies according to finish selection.
- Certified to meet and exceed the following codes and standards:  
ASME A112.18.1-2005/CSAB125.1-2005

Specifications

*Series 1600*

**Wall/Vessel Lav Set**

**Nuance  
1.163807S**

**(1.163807ST - Trim Only)**

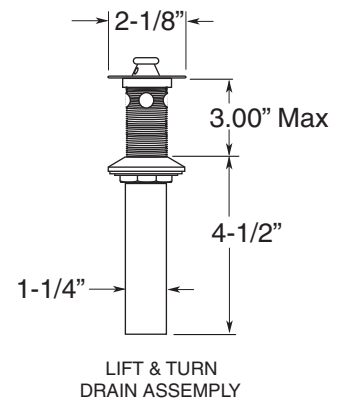
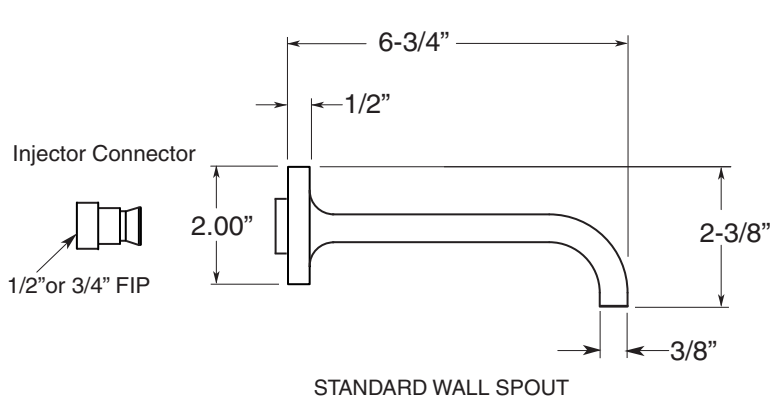
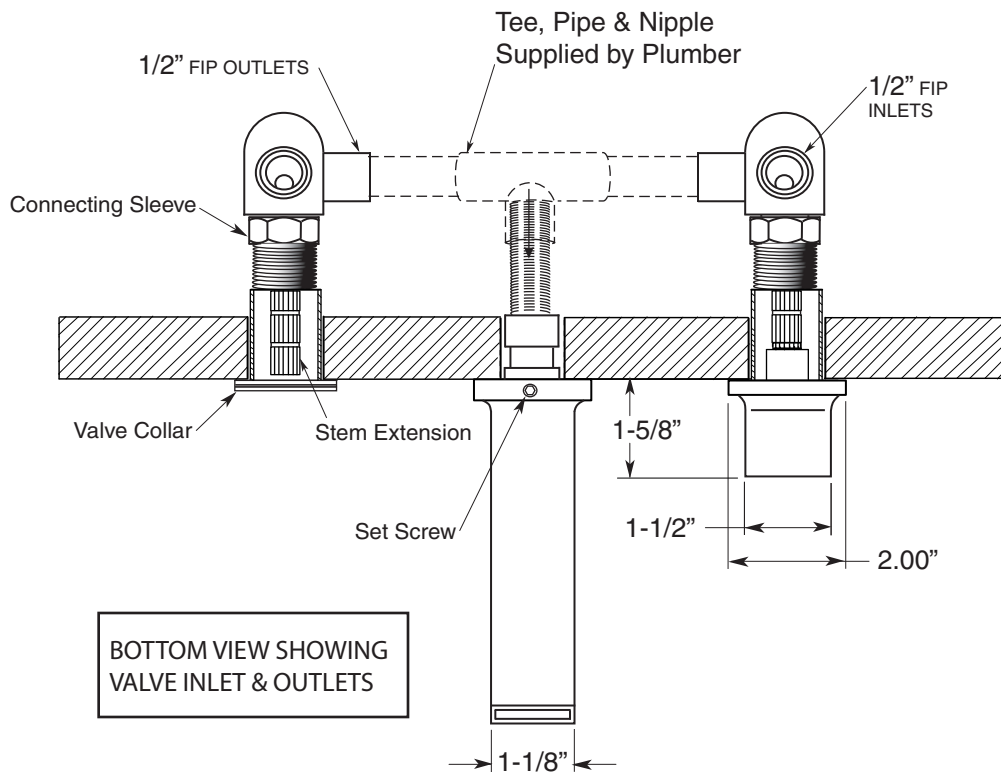

Note: Measurements are subject to change or cancellation. No responsibility is assumed for use of superseded or voided pages.