

STEMMA IN-WALL VESSEL FAUCET, MODEL 5339.451

- Contemporary minimalist styling, designed for use with high-profile countertop vessels
- In-wall mounting, includes faucet mounting kit, 6-1/2" (165mm) and 8" (203mm) spouts, and grid drain with overflow
- Adjustable spout length from 9-5/16" to 13-5/16" (237mm to 338mm)
- Cast brass construction
- Quarter-turn washerless ceramic disc valve cartridges
- Installs on 8" (203mm) centers

□ Specify finish: chrome or stainless steel



Maximum Flow Rate: 2.2 gpm (8.3 L/min.)

Low Lead: Meets NSF 61/Section 9 & Prop 65 lead requirements

CODES AND STANDARDS

These products meet or exceed the following codes and standards:

ASME A112.18.1
CSA B125
NSF 61/Section 9

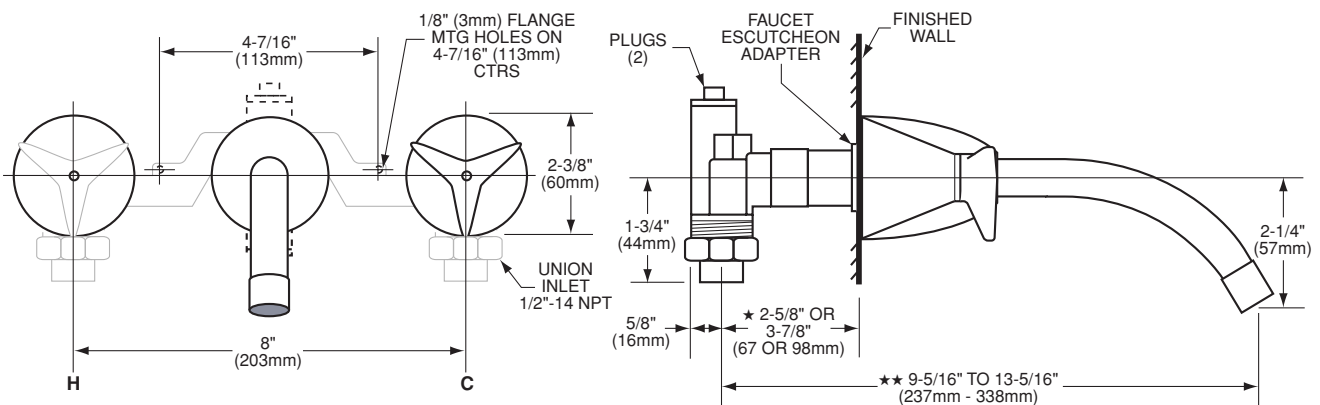
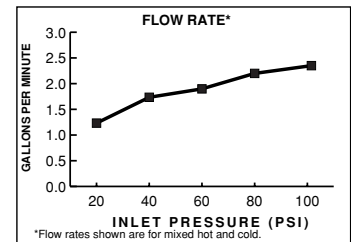

NOTES:

- ★ MINIMUM ROUGHIN IS OBTAINED WITH ESCUTCHEON ADAPTER THREADED SOCKETS INSTALLED WITH THREADED SECTION FACING CASTING, AND FAUCET STEM ADAPTER GROOVED SECTION FACING CASTING; MAXIMUM ROUGHIN IS OBTAINED BY REVERSING POSITIONS OF THREADED SOCKETS AND FAUCET STEM ADAPTERS.
- ★★ RANGE OF DIMENSIONS SHOWN ARE FOR 8" (203MM) SPOUT; REDUCE DIMENSIONS BY 1-1/2" (38MM) WHEN 6-1/2" (165MM) SPOUT IS USED. PROVIDE CROSS-BRACE FOR SUITABLE REINFORCEMENT.